

Over-Underpass Module (OUM)

Technical Data Sheet

The Over-Underpass Module (OUM) ensures the transfer of samples between different automation track areas of big laboratories, facilitating the free movement of people throughout the facility. The module is equipped with two elevators and a dedicated track section above the main track to transfer sample tubes (capped and uncapped) and empty carriers from one area to the other, with bidirectional carrier flow.

The OUM can connect:

- A. Two sections of the same automation system
- B. Two different automation systems

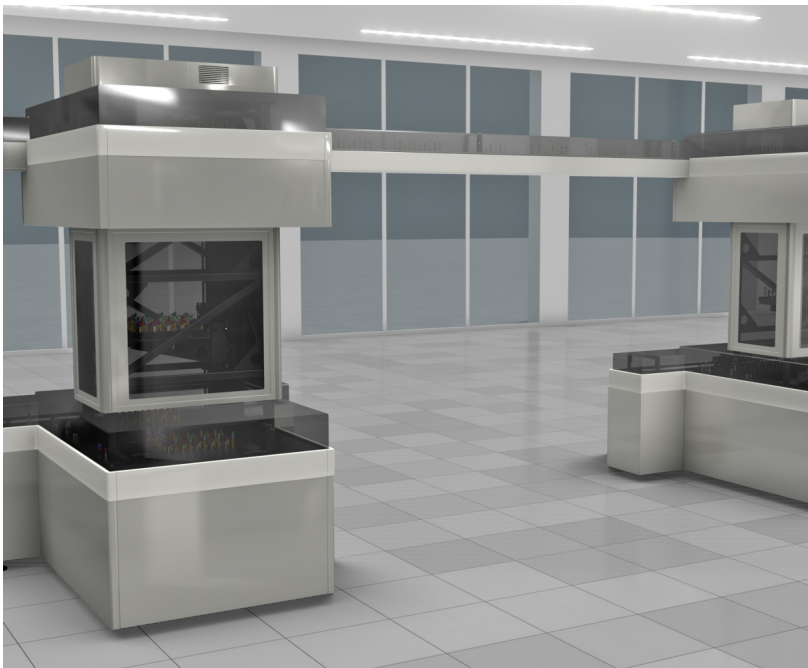

Benefits

- > Enables free movement of people throughout the lab
- > Automatic sample tubes transportation between different sections of the same automation track or different automation tracks
- > Maintenance and guarantee of sample tubes traceability after the transfer between different sections of the same automation track or different automation tracks
- > Transfer to OUM does not generate sample resuspension
- > Easy sample routing to the connected track with OUM when modules and/or analyzers of the original track are not available due to maintenance or other technical operations

Applications

- > Connection between different automation areas installed on the same lab floor in presence of space constraints
- > Connection between different automation tracks at the same lab floor to complete specific testing not available in one of the two automation systems

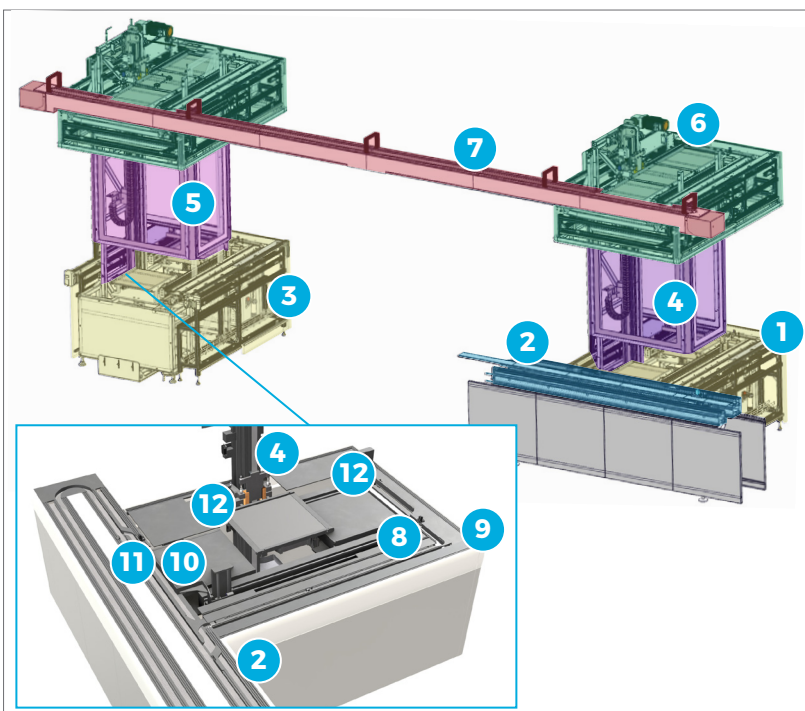

- | | |
|-------------------|-------------------|
| ① Main Floor | ⑦ Auxiliary Track |
| ② Buffer Lane | ⑧ Entry Bay |
| ③ Tower | ⑨ Entry Pit Lane |
| ④ Elevator | ⑩ Exit Bay |
| ⑤ Elevator Shaft | ⑪ Exit Pit Lane |
| ⑥ Auxiliary Floor | ⑫ Movers |

Main Features

Throughput	Up to 1000 tubes/h (both directions)
Walk-away capacity	/
Tube specifications	
Sample type	Spun and Unspun
Cap type	Capped and Uncapped
Dimensions (mm)	13x75, 13x100, 16x75, 16x100
Position along the automation	Depends on the designed function for the automation

The maximum throughput calculations are obtained in optimized and standardized conditions, as tested by Inpeco.

Other Features

- > The OUM is made of two Towers connected with an Auxiliary Track located above the main track, to move carriers from one side to the other
- > The Tower is equipped with an elevator which travels between two floors, where carriers are loaded and unloaded
- > Each Tower has two floors: the Main Floor (at the main track level) and the Auxiliary Floor (at the auxiliary track level)
- > A floor features two bays, surrounding the Elevator Shaft: an Entry Bay to unload carriers from the track and an Exit Bay to load them on the track
- > Movers allow to transfer carriers:
 - from the Entry Pitlane to the Entry Bay and then to elevator on one side
 - from the elevator to the Exit Bay and then to the Exit Pit lane on the other side

Technical Specifications

Dimensions (LxHxD) (mm)	1300x2975x1580(single tower)	Maximum continuous current (A)	/
Main clearances (left x right x front) (mm)	800x800x800; minimum height for operator's walking is 2400 mm minimum width for operator's walking is 2250 mm	Maximum alternate current (A)	4.2
Weight (Kg)	1530	Total power consumption (W)	966
Compressed air (NL/min)	38.12	Heat (BTU/h)	2627.5
Power inlet point	230 Vac		

Technical Drawing

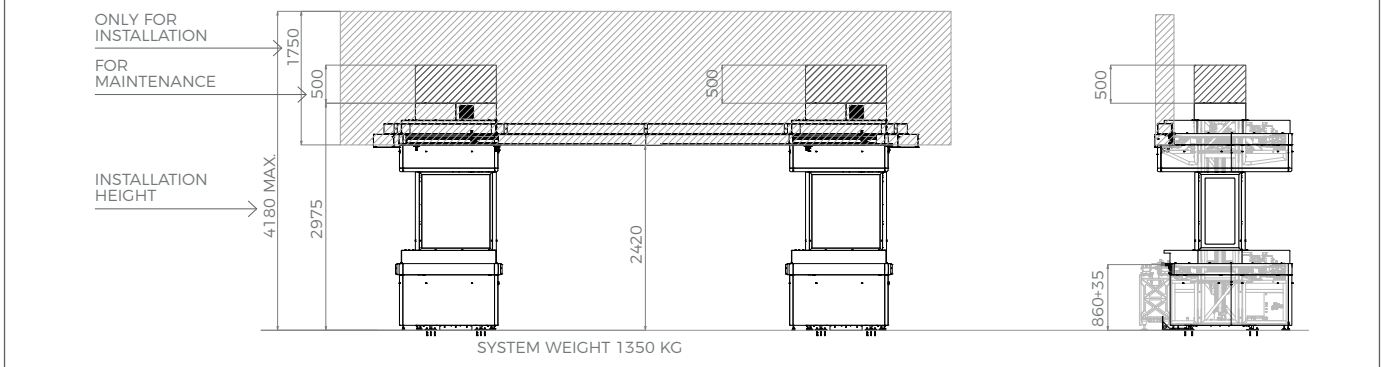

Module dimensions and clearances expressed in mm.

Part Numbers	FlexLab™	FlexLab™ for High Throughput
Interface	N.A.	FLX-261-10
Slot	N.A.	FLX-561-10

N.A. = Not Available.

Ordinary Maintenance

Operator ¹	/
Service ²	Every 90-180 days, according to operations

¹ According to Operation Manual. ²The periodicity depends also on the routine tubes/day. For more details refer to Service Manual.